

Safety Controller CPU Module User's Manual (Hardware)

Mitsubishi Electric Corporation
2-7-3 Marunouchi, Chiyoda-ku, Tokyo, Japan
Mitsubishi Electric Europe BV
Gothaer strasse 8, 40880 Ratingen, Germany

All rights reserved • Specified product properties and technical data do not represent a guarantee declaration.

MODEL	WS-CPU-U-HW-E
MODEL CODE	13JZ91
IB(NA)-0800527ENG-B(1407)SICK	

© 2014 MITSUBISHI ELECTRIC CORPORATION

Precautions regarding warranty and specifications

MELSEC-WS series products were jointly developed and manufactured by Mitsubishi and SICK AG, Industrial Safety Systems, in Germany. Note that there are some precautions regarding warranty and specifications of MELSEC-WS series products.

<Warranty>

- The gratis warranty term of the product shall be for one (1) year after the date of delivery or for eighteen (18) months after manufacturing, whichever is less.
- The onerous repair term after discontinuation of production shall be for four (4) years.
- Mitsubishi shall mainly replace the product that needs a repair.
- It may take some time to respond to the problem or repair the product depending on the condition and timing.

<Specifications>

- General specifications of the products differ.

	MELSEC-WS	MELSEC-Q	MELSEC-QS
Operating ambient temperature <i>Température ambiante de fonctionnement</i>	-25 to 55°C ^{*1} -25 à 55°C ^{*1}	0 to 55°C 0 à 55°C	0 to 55°C 0 à 55°C
Operating ambient humidity	10 to 95%RH	5 to 95%RH	5 to 95%RH
Storage ambient temperature	-25 to 70°C	-25 to 75°C	-40 to 75°C
Storage ambient humidity	10 to 95%RH	5 to 95%RH	5 to 95%RH

*1: When the WS0-GCC100202 is included in the system, operating ambient temperature will be 0 to 55°C.

*1: Avec un module WS0-GCC100202 inclus dans le système, la température ambiante de service est de 0 à 55°C.

- EMC standards that are applicable to the products differ.

	MELSEC-WS	MELSEC-Q, MELSEC-QS
EMC standards	EN 61000-6-2, EN 55011	EN 61131-2

1 About this document

This document is the original manual.

1.1 Documentations for the MELSEC-WS system

This manual describes the mounting of the CPU module of a MELSEC-WS safety controller.

Mounting of the MELSEC-WS network modules (WS0-GETH and WS0-GCC1), safety I/O modules (WS0-XTIO and WS0-XTDI) and the relay output module (WS0-4RO) is described in separate manuals.

The installation, configuration and commissioning of the MELSEC-WS safety controller are described in the "Safety Controller User's Manual" and "Safety Controller Setting and Monitoring Tool Operating Manual".

Title	Number
Safety Controller User's Manual	WS-CPU-U-E (13JZ32)
Safety Controller Ethernet Interface User's Manual	WS-ET-U-E (13JZ33)
Safety Controller CC-Link Interface User's Manual	WS-CC-U-E (13JZ45)
Safety Controller Setting and Monitoring Tool Operating Manual	SW1DNNWS0ADR-B-O-E (13JU67)

1.2 Function of this document

This manual instructs the technical staff of the machine manufacturer and/or of the machine operator on the safe operating of the CPU module of the MELSEC-WS safety controller.

In addition mounting protective devices also requires specific technical skills which are not detailed in this documentation.

This manual does not provide instructions for operating the machine in which the safety controller is, or will be, integrated. Information of this kind will be found in the manuals for the machine.

2 On safety

This chapter deals with your own safety and the safety of the equipment operators.

- Please read this chapter carefully before beginning with the installation.

2.1 Qualified safety personnel

The MELSEC-WS safety controller may only be installed by qualified safety personnel.

Qualified safety personnel are defined as persons who ...

- have undergone the appropriate technical training **and**
- who have been instructed by the responsible machine operator in the operation of the machine and the current valid safety guidelines **and**
- have access to the MELSEC-WS manuals and have read and familiarized themselves with them **and**
- have access to the manuals for the protective devices (e.g. light curtains) connected to the safety controller and have read and familiarized themselves with them.

2.2 Applications of the device

The MELSEC-WS safety controller is a configurable controller for safety applications. It can be used

- in accordance with IEC 61508 to SIL 3
- in accordance with IEC 62061 to SILCL 3
- in accordance with EN/ISO 13849-1 up to Performance Level e

The degree of safety actually attained depends on the external circuit, the realization of the wiring, the parameter configuration, the choice of the pick-ups and their location at the machine.

Opto-electronic and tactile safety sensors (e.g. light curtains, laser scanners, safety switches, sensors, emergency-stop buttons) are connected to the safety controller and are linked logically. The corresponding actuators of the machines or systems can be switched off safely via the switching outputs of the safety controller.

2.3 Correct use



ATTENTION

The MELSEC-WS safety controller fulfils the requirements of Class A (industrial applications) in accordance with the "Interference emission" basic specifications!

Le contrôleur de sécurité MELSEC-WS a été conçu en conformité aux exigences des appareils de Classe A (applications industrielles) pour ce qui concerne les spécifications de base dans le domaine des "émissions d'interférences" !

The MELSEC-WS safety controller is therefore only suitable for use in an industrial environment and not for private use.

Le contrôleur de sécurité MELSEC-WS peut donc s'utiliser dans un environnement industriel mais n'a pas été prévu pour un usage domestique.

The MELSEC-WS safety controller may only be used within specific operating limits (voltage, temperature, etc., refer to the technical data and to the section "Application areas of the device"). It may only be used by qualified safety personnel and only at the machine at which it was mounted and initially commissioned by qualified safety personnel in accordance with the "Safety Controller User's Manual".

The modules of the MELSEC-WS safety controller conform to Class A, Group 1, in accordance with EN 55011. Group 1 encompasses all the ISM devices in which intentionally generated and/or used conductor-bound RF energy that is required for the inner function of the device itself occurs.

Mitsubishi Electric Corporation accepts no claims for liability if the equipment is used in any other way or if modifications are made to the device, even in the context of mounting and installation.

UL/CSA applications:

- Use 60°C/75°C conductors.
- The terminal tightening torque must be 5-7 lbs in.
- To be used in a Pollution Degree 2 environment only.
- Memory plug and CPU module shall be supplied by an isolating power source protected by an UL248 fuse, rating 42.4VDC which is the maximum voltage requirements of UL508.
- The safety functions are not evaluated by UL. The approval is accomplished according to UL508, general use applications.

Applications UL/CSA:

- *Utiliser des conducteurs 60°C/75°C.*
- *Le couple de serrage des bornes doit être de 5-7 lbs in.*
- *À utiliser uniquement en environnement polluant de degré 2.*
- *La prise mémoire et le module CPU doivent être alimentés à partir d'une source isolée protégée par un fusible UL248, d'une tension nominale de 42,2V cc, ce qui est le maximum admissible pour UL508.*
- *Les fonctions de sécurité n'ont pas été évaluées par UL. L'agrément a été accordé selon UL508 pour applications universelles.*

2.4 General protective notes and protective measures



ATTENTION

Observe the protective notes and measures! Respecter les consignes de sécurité et mesures de protection !

Please observe the following items in order to ensure proper use of the MELSEC-WS safety controller.
Pour garantir une utilisation correcte du contrôleur de sécurité MELSEC-WS, veuillez observer les points suivants.

- When mounting, installing and using the MELSEC-WS safety controller, observe the standards and directives applicable in your country.
- The national rules and regulations apply to the installation, use and periodic technical inspection of the MELSEC-WS safety controller, in particular:
 - Machinery Directive 2006/42/EC
 - EMC Directive 2004/108/EC
 - Provision and Use of Work Equipment Directive 2009/104/EC
 - Low-Voltage Directive 2006/95/EC
 - Work safety regulations/safety rules
- Manufacturers and owners of the machine on which a MELSEC-WS safety controller is used are responsible for obtaining and observing all applicable safety regulations and rules.
- It is imperative that the notices, in particular the test notices of the manual must be observed.
- The tests must be carried out by qualified safety personnel or specially qualified and authorized personnel and must be recorded and documented to ensure that the tests can be reconstructed and retraced at any time by third parties.

2.5 Disposal

Disposal of unusable or irreparable devices should always occur in accordance with the applicable country-specific waste-disposal regulations (e.g. European Waste Code 16 02 14).

3 Conditions of use for the product

- (1) Although MELCO has obtained the certification for Product's compliance to the international safety standards IEC 61508, EN 954-1/ISO 13849-1 from TUV Rheinland, this fact does not guarantee that Product will be free from any malfunction or failure. The user of this Product shall comply with any and all applicable safety standard, regulation or law and take appropriate safety measures for the system in which the Product is installed or used and shall take the second or third safety measures other than the Product. MELCO is not liable for damages that could have been prevented by compliance with any applicable safety standard, regulation or law.
- (2) MELCO prohibits the use of Products with or in any application involving, and MELCO shall not be liable for a default, a liability for defect warranty, a quality assurance, negligence or other tort and a product liability in these applications.
 - 1) power plants,
 - 2) trains, railway systems, airplanes, airline operations, other transportation systems,
 - 3) hospitals, medical care, dialysis and life support facilities or equipment,
 - 4) amusement equipment,
 - 5) incineration and fuel devices,
 - 6) handling of nuclear or hazardous materials or chemicals,
 - 7) mining and drilling,
 - 8) and other applications where the level of risk to human life, health or property are elevated.

4 Product description

4.1 CPU modules WS0-CPU0, WS0-CPU1 and WS0-CPU3

The CPU modules WS0-CPU0, WS0-CPU1 or WS0-CPU3 are the central process unit of the entire system in which all the signals are monitored and processed logically in accordance with the configuration stored in the memory plug. The outputs of the system are switched as a result of the processing, whereby the FLEXBUS+ backplane bus serves as the data interface.

The memory plug has to be ordered separately, refer to the "Safety Controller User's Manual".

The CPU modules further more have an RS-232 interface with the following functions:

- Transferring the configuration from the MELSEC-WS Setting and Monitoring Tool to the memory plug or the connected SICK EFI-compatible device
- Uploading the configuration from the memory plug or the connected SICK EFI-compatible device to the MELSEC-WS Setting and Monitoring Tool
- Online monitoring of the MELSEC-WS safety controller

The WS0-CPU1 and WS0-CPU3 modules have two more EFI interfaces. If SICK EFI-compatible devices are connected, a functional extension at the sensors is then possible by simple means.

The WS0-CPU3 module has following interfaces as well.

- USB interface for the settings and diagnostics using the MELSEC-WS Setting and Monitoring Tool
- Flexi Line interface that enables safety communications between MELSEC-WS safety controllers

4.2 Display elements

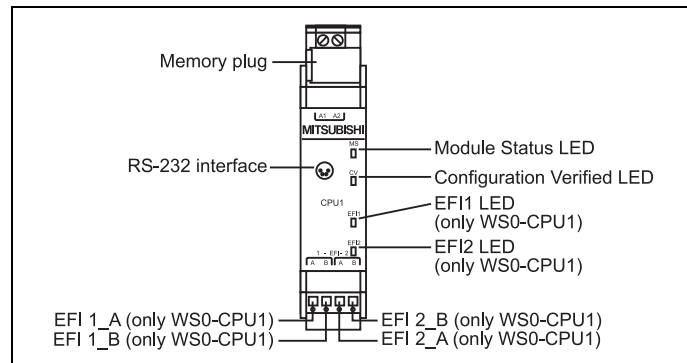

WS0-CPU0 and WS0-CPU1 modules

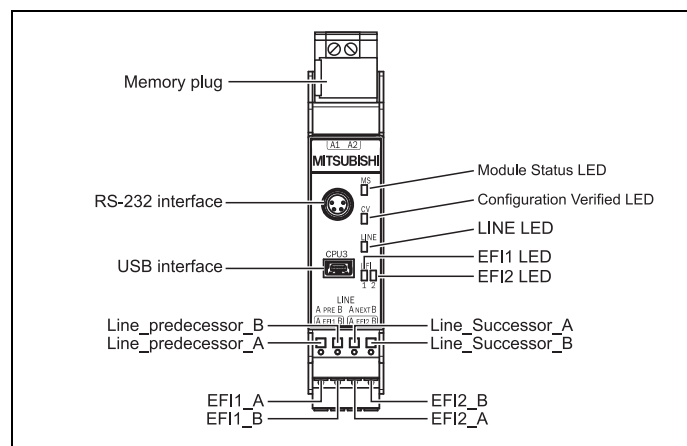

WS0-CPU3 module

4.2.1 Displays of the MS LED (module status)

MS LED	Meaning
○	Supply voltage lies outside range
⊛ (red/green 1Hz)	A self test is being carried out or the system is being initialized
⊛ (green 1Hz)	System is in Stop state
⊛ (green 2Hz)	Identify (e.g. for Flexi Link)
● (green)	System is in Run state
⊛ (red 1Hz)	Invalid configuration
⊛ (red 2Hz)	Critical error in the system, possibly in this module. Application is stopped. All outputs are switched off.
● (red)	Critical error in the system, possibly in another module. Application is stopped. All outputs are switched off.

Symbol meaning:

○: LED Off, ●: LED Lights up, ⊛: LED Flashes

4.2.2 Displays of the CV LED (configuration status)

CV LED	Meaning
○	Configuration in progress
⊛ (yellow 2Hz)	Storing of configuration data in the non-volatile memory
⊛ (yellow 1Hz)	Unverified configuration
● (yellow)	Valid configuration

4.2.3 Displays of the EFI LEDs (only WS0-CPU1 and WS0-CPU3)

EFI LED (EFI1 or EFI2)	Meaning
○	OK
● (red)	Waiting for integration of any SICK EFI-compatible device or Flexi Link station after power up
⊛ (red 1Hz)	Error, e.g.: <ul style="list-style-type: none"> Any expected SICK EFI-compatible device or Flexi Link station not found within 3 minutes Integration check failed Communication interruption SICK EFI-compatible device address conflict Flexi Link ID conflict
⊛ (red 2Hz, alternating)	Identify, (e.g. for Flexi Link)

4.2.4 Displays of the LINE LED (only WS0-CPU3)

LINE LED	Meaning
○	Flexi Line is not set and not operating.
● (green)	Flexi Line is operating.
⊛ (green 1Hz)	Flexi Line is waiting for an adjacent station.
⊛ (green 2Hz)	Perform teaching.
⊛ (red/green 2Hz)	Set Flexi Line.
⊛ (red 1Hz)	An error has occurred on Flexi Line.
● (red)	Flexi Line is stopped because of a major error.

4.3 Terminal assignment

Affectation des bornes

4.3.1 Pin assignment of RS232 interface

Affectation des broches d'interface RS232

Plug/socket Fiche/prise	Pin Broche	Signal Signal
	1	Reserved En réserve
	2	RxD
	3	GND (Internally electrically connected with connection A2 of the CPU module) GND (Raccordé électriquement à l'intérieur sur connexion A2 du module CPU)
	4	TxD

4.3.2 Terminal assignment of memory plugs WS0-MPL0 and WS0-MPL1

Affectation des bornes de prise mémoire WS0-MPL0 et WS0-MPL1

Terminal Borne	Assignment Affectation
A1	24VDC
A2	0VDC

4.4 Wiring example

Wiring of the emergency stop pushbuttons, start switches, stop switches, and reset switches

- Dual-channel wiring (with test pulse outputs)^{*1}

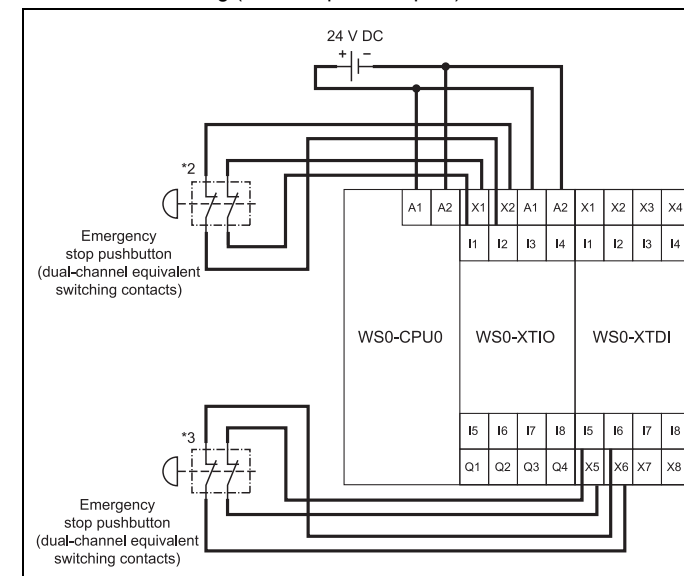

- *1: Use the following terminal combinations for dual-channel input wiring.
- WS0-XTIO: ((I1 and X1) (I2 and X2)), ((I3 and X1) (I4 and X2)), ((I5 and X1) (I6 and X2)), ((I7 and X1) (I8 and X2))
- WS0-XTDI: ((I1 and X1) (I2 and X2)), ((I3 and X3) (I4 and X4)) to ((I7 and X7) (I8 and X8))

- *2: Connect an emergency stop pushbutton (with dual-channel equivalent switching contacts for direct operation) between the I1 to I8 (input) terminals and the X1 and X2 (test pulse output) terminals.

- *3: Connect an emergency stop pushbutton (with dual-channel equivalent switching contacts for direct operation) between the I1 to I8 (input) terminals and the X1 to X8 (test pulse output) terminals.

- *1: Utiliser les combinaisons de bornes ci-après pour le câblage d'entrée double-voie.

- WS0-XTIO: ((I1 and X1) (I2 and X2)), ((I3 and X1) (I4 and X2)), ((I5 and X1) (I6 and X2)), ((I7 and X1) (I8 and X2))
- WS0-XTDI: ((I1 and X1) (I2 and X2)), ((I3 and X3) (I4 and X4)) à ((I7 and X7) (I8 and X8))

- *2: Raccorder un bouton-poussoir d'arrêt d'urgence (avec contacts de commutation équivalente sur double canal pour actionnement direct) entre les bornes I1 à I8 (entrée) et les bornes X1 et X2 (sortie d'impulsions d'essai).

- *3: Raccorder un bouton-poussoir d'arrêt d'urgence (avec contacts de commutation équivalente sur double canal pour actionnement direct) entre les bornes I1 à I8 (entrée) et les bornes X1 à X8 (sortie d'impulsions d'essai).

5 Mounting/Dismantling



ATTENTION

The MELSEC-WS safety controller is only suitable for mounting in a control cabinet with at least IP 54 degree of protection.

While supply voltage is applied, modules must not be plugged to nor be removed from the MELSEC-WS safety controller.

Le contrôleur de sécurité MELSEC-WS ne peut être installé que dans une armoire de commande avec un degré de protection IP 54 ou mieux.

Quand la tension d'alimentation est appliquée, les modules ne doivent pas être enfichés sur ou retirés du contrôleur de sécurité MELSEC-WS.

5.1 Mounting the modules

- In a MELSEC-WS safety controller, the CPU module is positioned at the far left and the two optional network modules follow directly. Only then do the safety I/O modules follow. The WS0-4RO module has to be mounted at the far right.
- The modules are located in a 22.5mm wide modular system for 35mm DIN rails to IEC/EN 60715.
- The connection between the modules is effected by means of the plug connection integrated in the housing.
- Mount the modules in accordance with EN 50274
- Ensure that suitable ESD protective measures are also taken during mounting. Otherwise the FLEXBUS+ backplane bus may be damaged.
- Take suitable measures to ensure that foreign matter does not enter the connector openings, in particular that of the memory plug.

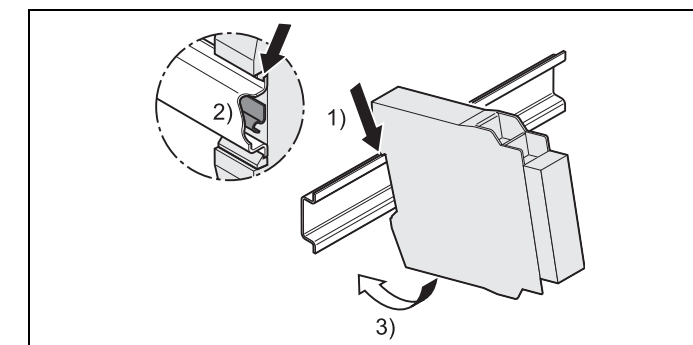

⇒ Make sure that the voltage supply of the MELSEC-WS safety controller is switched off.

⇒ Hang the device onto the DIN rail (1).

⇒ Ensure that the earthing spring contact is positioned correctly (2). The earthing spring contact of the module must contact the DIN rail securely to allow electrical conductivity.

⇒ Snap the module onto the DIN rail by pressing it lightly in the direction of the arrow (3).

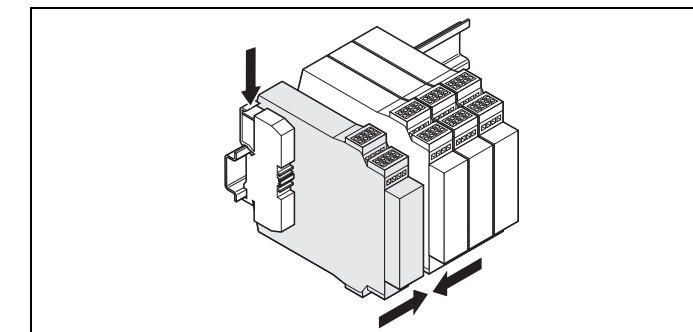

⇒ If there are several modules, slide the modules together individually in the direction of the arrow until the side plug connection latches in.

⇒ Install the end clips on the left and right.

5.2 Steps for dismantling the modules

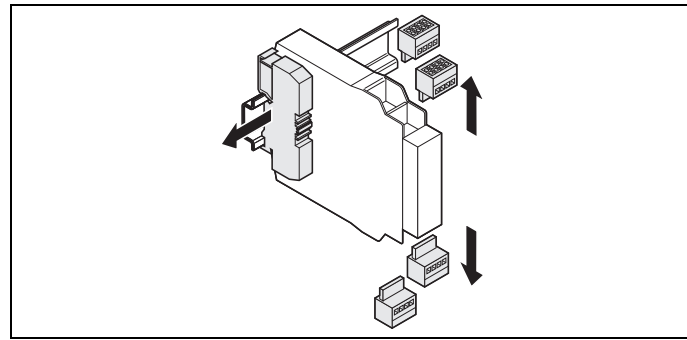

⇒ Remove the removable terminals with wiring and the end clips.

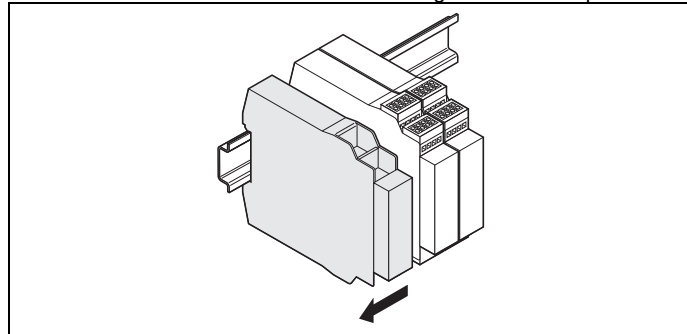

⇒ If there are several modules, slide the modules away from each other individually in the direction of the arrow until the side plug connection is separated.

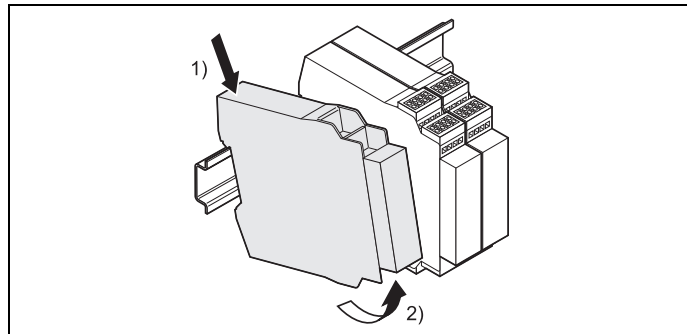

⇒ Press the module downwards at the rear (1)) and remove it from the DIN rail in the direction of the arrow while keeping it pressed down (2)).

6 Electrical installation



ATTENTION

**De-energize the entire system!
Mettez le système entièrement hors tension !**

The system could start up unexpectedly while you are connecting the devices.
Le système pourrait être mis en marche par inadvertance pendant qu'on connecte les dispositifs.

**Observe the relevant safety standards!
Observez les normes de sécurité pertinentes!**

All safety related parts of the installation (cabling, connected sensors and actuators, configuration settings, EDM) must be according to the relevant safety standards (e.g. IEC 62061 or EN/ISO 13849-1).

Tout matériel ou logiciel ayant des implications de sécurité (câblage, capteurs et actionneurs à raccorder, paramètres de configuration, EDM) doivent être conformes aux normes de sécurité applicables (par exemple, IEC 62061 ou EN/ISO 13849-1).

- The MELSEC-WS safety controller fulfils the EMC requirements in accordance with the basic specification IEC 61000-6-2 for industrial use.
- Carry out the electrical installation in accordance with EN 60204-1
- To ensure full electromagnetic compatibility (EMC), the DIN rail has to be connected to functional earth (FE).
- The voltage supply of the devices must be capable of buffering brief mains voltage failures of 20ms as specified in IEC 60204-1.
- The voltage supply has to fulfil the regulations for extra-low voltages with safe separation (SELV, PELV) in accordance with IEC 60664 and EN 50178 (equipment of electrical power installation with electronic devices).
- You must connect all the modules of the MELSEC-WS safety controller, the connected protective devices as well as the voltage supply/ies with the same 0VDC (GND).
- All connected pick-ups and downstream controllers as well as wiring and installation have to fulfil the required safety characteristics.
- If a module is replaced the correct terminal assignment has to be guaranteed, for example by labelling or suitable cable routing.
- For further information that is to be taken into consideration when the MELSEC-WS safety controller is used, refer to the "Safety Controller User's Manual" and "Safety Controller Setting and Monitoring Tool Operating Manual".

7 Configuration and commissioning



ATTENTION

**Do not commission without a check by qualified safety personnel!
Ne pas procéder à la mise en service sans qu'un personnel de sécurité qualifié ait effectué un contrôle.**

Before initial commissioning of a system using a MELSEC-WS safety controller, it must be checked and released by qualified safety personnel. Document the result of the safety check.

La première mise en service d'un système utilisant un contrôleur de sécurité MELSEC-WS ne doit être effectuée qu'après contrôle et sur autorisation délivrée par un personnel qualifié. Les résultats du contrôle de sécurité doivent être dûment documentés et suivis.

The MELSEC-WS safety controller can be configured by the Setting and Monitoring Tool connected to the RS-232 interface or USB interface (only WS0-CPU3 module) of a CPU module, or the port of an Ethernet interface module.

- Note
- The Setting and Monitoring Tool is required to configure and commission the MELSEC-WS safety controller.
 - The system configuration of the complete MELSEC-WS safety controller is stored in the memory plug. The system does not have to be reconfigured when a module is replaced.
 - For the diagnostics after module replacement with the higher version (for instance, upgraded from V1.11.0 to V2.01.0), the Setting and Monitoring Tool version 1.7.0 is required.

8 Technical data

Safety-related parameters

This information relates to an ambient temperature of +40°C, which is normally used for the statistical calculation of the values.

	WS0-CPU0	WS0-CPU1/3
Safety Integrity Level	SIL3 (IEC 61508)	
SIL claim limit	SILCL3 (IEC 62061)	
Category	Category 4 (EN/ISO 13849-1)	
Performance Level	PLe (EN/ISO 13849-1)	
PFHd	1.07×10^{-9}	1.69×10^{-9}
PFHd for Flexi Line station ^{*1}	-	CPU1: - CPU3: 0.40×10^{-9}
T _M (mission time)	20 years (EN/ISO 13849-1)	

*1 Applies for a CPU module WS0-CPU3 that is used exclusively for routing information via Flexi Line.

General data

	WS0-CPU0	WS0-CPU1/3
Protection class	III (IEC 61140)	
Enclosure rating	IP20 (IEC 60529)	
Ambient temperature in operation <i>Température ambiante de fonctionnement</i>	-25 ... +55°C -25 à +55°C	
Storage temperature	-25 ... +70°C	
Humidity	10% ... 95%, non-condensing	
Climatic conditions	55°C, 95% relative humidity (IEC 61131-2), No corrosive gases	
Operating altitude	Max. 2000 m above sea level (80 kPa)	
Vibration resistance	5-150 Hz/1g (EN 60068-2-6) 10-500 Hz/3gRMS (IEC 60068-2-64)	
Shock resistance	Continuous shock Single shock	
	10g, 16ms (IEC 60068-2-27) 30g, 11ms (IEC 60068-2-27)	
Electromagnetic compatibility	Class A (IEC 61000-6-2, EN 55011)	
Number of EFI interfaces	0	2
Number of Flexi Line interfaces	0	CPU1: 0 CPU3: 2
Data interface	Backplane bus (FLEXBUS+)	
Configuration interface	RS-232	CPU1: RS-232 CPU3: RS-232, USB2.0 (mini b)
Cross-section of connecting wires <i>Taille des fils de raccordement</i>	Single-core or finely stranded: $1 \times 0.14 \dots 2.5 \text{ mm}^2$ (26 to 13 AWG) or $2 \times 0.14 \dots 0.75 \text{ mm}^2$ (26 to 18 AWG) Finely stranded with wire end ferrules: $1 \times 0.25 \dots 2.5 \text{ mm}^2$ (23 to 13 AWG) or $2 \times 0.25 \dots 0.5 \text{ mm}^2$ (23 to 20 AWG) <i>Monobrin ou fine torsade:</i> $1 \times 0.14 \dots 2.5 \text{ mm}^2$ (26 à 13 AWG) ou $2 \times 0.14 \dots 0.75 \text{ mm}^2$ (26 à 18 AWG) <i>Fine torsade avec manchon d'extrémité EN 46228:</i> $1 \times 0.25 \dots 2.5 \text{ mm}^2$ (23 à 13 AWG) ou $2 \times 0.25 \dots 0.5 \text{ mm}^2$ (23 à 20 AWG)	
EFI or Flexi Line connection method	-	Dual level spring clamp terminals
Cross-section of EFI connecting wires	-	Single-core or finely stranded: $0.2 \dots 1.5 \text{ mm}^2$ (24 to 15 AWG) Finely stranded with wire end ferrule: $0.25 \dots 1.5 \text{ mm}^2$ (23 to 15 AWG)
Dimensions (W × H × D)	22.5 × 96.5 × 120.8mm	22.5 × 101.7 × 120.8mm
Weight	111g (+/- 5%)	119g (+/- 5%)

Power supply unit (A1, A2) via memory plug WS0-MPL0 or WS0-MPL1

	WS0-CPU0	WS0-CPU1/3
Supply voltage	24VDC (16.8 ... 30VDC)	
Supply voltage UL/CSA applications	24VDC	
Type of supply voltage	PELV or SELV The current of the power supply unit that supplies the CPU module has to be limited to a maximum of 4A – either by the power supply unit itself or by a fuse	
Overvoltage category	II (IEC61131-2)	
Power consumption	Max. 2.5W	
Switch-on time	Max. 18s	

Country/Region	Sales office/Tel
USA	Mitsubishi Electric Automation Inc. 500 Corporate Woods Parkway, Vernon Hills, IL 60061, USA Tel : +1-847-479-2100
Brazil	MELCO-TEC Representacao Comercial e Assessoria Tecnica Ltda. Av. Paulista, 1439, cj74, Bela Vista, Sao Paulo CEP: 01311-200-SP Brazil Tel : +55-11-3146-2200
Germany	Mitsubishi Electric Europe B.V. German Branch Gothaer Strasse 8, D-40880 Ratingen, Germany Tel : +49-2102-486-0
UK	Mitsubishi Electric Europe B.V. UK Branch Travellers Lane, Hatfield, Hertfordshire, AL10 8XB, UK. Tel : +44-1707-27-6100
Italy	Mitsubishi Electric Europe B.V. Italian Branch Viale Colleoni 7-20864 Agrate Brianza (Milano), Italy Tel : +39-039-60531
Spain	Mitsubishi Electric Europe B.V. Spanish Branch Carretera de Rubi 76-80.AC.420, E-08190 Sant Cugat del Valles (Barcelona), Spain Tel : +34-93-565-3131
France	Mitsubishi Electric Europe B.V. French Branch 25, Boulevard des Bouvets, F-92741 Nanterre Cedex, France Tel : +33-1-5568-5568
Czech Republic	Mitsubishi Electric Europe B.V.-o.s.Czech office Avenir Business Park, Radicka 751/113e, 158 00 Praha5, Czech Republic Tel : +420-251-551-470
Poland	Mitsubishi Electric Europe B.V. Polish Branch ul. Krakowska 50, 32-083 Balice, Poland Tel : +48-12-630-47-00
Russia	Mitsubishi Electric Europe B.V. Russian Branch St.Petersburg office Piskarevsky pr. 2, bld 2, lit "Sch", BC "Benua", office 720; 195027, St. Petersburg, Russia Tel : +7-812-633-3497
South Africa	CBI-Electric. Private Bag 2016, ZA-1600 Isando, South Africa Tel : +27-11-977-0770
China	Mitsubishi Electric Automation (China) Ltd. No.1386 Hongqiao Road, Mitsubishi Electric Automation Center, Changning District, Shanghai, China Tel : +86-21-2322-3030
Taiwan	Setsuyo Enterprise Co., Ltd. 6F., No.105, Wugong 3rd Road, Wugu District, New Taipei City 24889, Taiwan, R.O.C. Tel : +886-2-2299-2499
Korea	Mitsubishi Electric Automation Korea Co., Ltd. 3F, 1480-6, Gayang-Dong, Gangseo-Gu, Seoul, 157-200, Korea Tel : +82-2-3660-9530
Singapore	Mitsubishi Electric Asia Pte, Ltd. Industrial Division 307, Alexandra Road, Mitsubishi Electric Building, Singapore, 159943 Tel : +65-6470-2308
Thailand	Mitsubishi Electric Automation (Thailand) Co., Ltd. Bang-Chan Industrial Estate No.111 Soi Senthai 54, T.Kannayao, A.Kannayao, Bangkok 10230 Thailand Tel : +66-2906-3238
Indonesia	P. T. Autoteknindo Sumber Makmur Muara Karang Selatan, Block A / Utara No.1 Kav. No. 11, Kawasan Industri Pergudangan, Jakarta-Utara 14440, P.O. Box 5045, Indonesia Tel : +62-21-663-0833
India	Mitsubishi Electric India Pvt. Ltd. 2nd Floor, Tower A & B, Cyber Greens, DLF Cyber City, DLF Phase-III, Gurgaon-122002 Haryana, India Tel : +91-124-463-0300
Australia	Mitsubishi Electric Australia Pty. Ltd. 348 Victoria Road PO BOX11, Rydalmere, N.S.W 2116, Australia Tel : +61-2-9684-7777

MITSUBISHI ELECTRIC CORPORATION

HEAD OFFICE : TOKYO BUILDING, 2-7-3 MARUNOUCHI, CHIYODA-KU, TOKYO 100-8310, JAPAN
NAGOYA WORKS : 1-14, YADA-MINAMI 5-CHOME, HIGASHI-KU, NAGOYA, JAPAN

When exported from Japan, this manual does not require application to the Ministry of Economy, Trade and Industry for service transaction permission.

Specifications subject to change without notice.

SICK SICK AG <http://www.sick.com/>