

FX_{1N}-4EX-BD Input Expansion Board

USER'S MANUAL

JY992D95001B

This manual contains text, diagrams and explanations which will guide the reader in the correct installation, safe use and operation of the FX_{1N}-4EX-BD Input Expansion Board and should be read and understood before attempting to install or use the unit. Further information can be found in the associated manuals list below.

Specifications are subject to change without notice

Guidelines for the Safety of the User and Protection of the FX_{1N}-4EX-BD.

This manual has been written to be used by trained and competent personnel. The definition of such a person or persons is as follows:

- a) Any engineer using the product associated with this manual, should be of a competent nature, trained and qualified to the local and national standards. These engineers should be fully aware of all aspects of safety with regards to automated equipment.
- b) Any commissioning or service engineer must be of a competent nature, trained and qualified to the local and national standards.
- c) All operators of the completed equipment should be trained to use that product in a safe and coordinated manner in compliance to established safety practices.

Note: The term 'completed equipment' refers to a third party constructed device which contains or uses the product associated with this manual.

Note's on the Symbols Used in this Manual

At various times through out this manual certain symbols will be used to highlight points of information which are intended to ensure the users personal safety and protect the integrity of equipment.



- 1) Indicates that the identified danger **WILL** cause physical and property damage.



- 2) Indicates that the identified danger could **POSSIBLY** cause physical and property damage.

- Under no circumstances will Mitsubishi Electric be liable or responsible for any consequential damage that may arise as a result of the installation or use of this equipment.
- All examples and diagrams shown in this manual are intended only as an aid to understanding the text, not to guarantee operation. Mitsubishi Electric will accept no responsibility for actual use of the product based on these illustrative examples.
- Owing to the very great variety in possible application of this equipment, you must satisfy yourself as to its suitability for your specific application.

Associated manuals

Manual name	Manual No.	Description
FX _{1S} Series Hardware Manual	JY992D83901	Describes contents related to hardware of FX _{1S} Series PLC such as specifications, wiring and installation.
FX _{1N} Series Hardware Manual	JY992D89301	Describes contents related to hardware of FX _{1N} Series PLC such as specifications, wiring and installation.
FX Programming Manual II	JY992D88101	Describes instructions in FX _{1S} /FX _{1N} /FX _{2N} /FX _{2NC} Series.

1. Introduction

The FX_{1N}-4EX-BD Input Expansion Board (hereafter referred to as "FX_{1N}-4EX-BD" or "Function expansion board") is a function expansion board to be installed in the FX_{1S} or FX_{1N} series programmable controller (hereafter referred to as "PLC"), to increase the input of four points.

1.1 Features of the FX_{1N}-4EX-BD

- 1) Additional increase of four input points.
- 2) Internal mounting in the top of the PLC meaning no need for change to the installation area of the PLC.
- 3) Additional inputs have special auxiliary relays allocated to each point, which are turned ON and OFF depending on the input state of the FX_{1N}-4EX-BD.
As special auxiliary relays are used in the PLC program for the input points, the additional inputs are not included in the regular system I/O count.

1.2 External Dimensions and Each Part Name

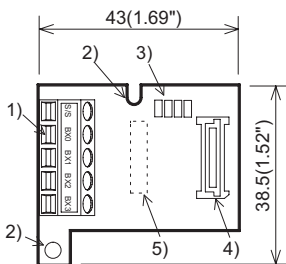

Dimensions: mm (inches)

Accessories : Top cover for board 1
M3 screw to mount board 2
M3 screw to fix top cover 1

- 1) Input terminal.
S/S : Power supply terminal
BX0 : Terminal of input BX0
BX1 : Terminal of input BX1
BX2 : Terminal of input BX2
BX3 : Terminal of input BX3
The top face of this connector is higher than the top face of the PLC panel cover by approximately 7 mm.
- 2) Mounting hole (2-φ3.5(0.14"))
- 3) Input LED
BX0 LED : The LED lights when BX0 is turn on.
BX1 LED : The LED lights when BX1 is turn on.
BX2 LED : The LED lights when BX2 is turn on.
BX3 LED : The LED lights when BX3 is turn on.
- 4) External port for display module FX_{1N}-5DM or memory cassette FX_{1N}-EEPROM-8L
- 5) External connector for PLC

1.3 System configuration

- Only one function expansion board can be used on one FX_{1S} or FX_{1N} series PLC main unit. Do not try to install two or more expansion boards.
- FX_{1N}-4EX-BD can be used together with an FX_{1N}-5DM. Refer to the FX_{1S} or FX_{1N} HARDWARE MANUAL when using the FX_{1N}-4EX-BD together with an FX_{1N}-5DM.
- When using with the memory cassette FX_{1N}-EEPROM-8L, only program transfer is possible. (The memory cassette cannot be connected permanently)

1.4 Applicable PLC

Series name	Applicable version
FX _{1S}	V2.0 or later
FX _{1N}	V2.0 or later

2. Installation



Caution

- 1) Do not use the function expansion board in environments that contain excessive or conductive dust, corrosive or flammable gas, moisture or rain, excessive heat, regular impact shocks or excessive vibration.
Use in these environment may cause electric shock, fire, malfunction, damage or deterioration of the product.
- 2) Cut off all phases of power source before installing / removing or performing wiring work on the unit in order to avoid electric shock or damage of product.
- 3) After the installation and wiring etc. replace the PLCs top cover before power ON.
- 4) Securely install the function expansion board, and fix to the PLC.
Defective contact can cause malfunction.

2.1 Mounting

Turn off all power to the PLC before installing the FX_{1N}-4EX-BD.

- a)** Top cover for use with FX_{1N}-4EX-BD (supplied as an accessory)
- b)** M3 screw to fix top cover (supplied as an accessory)
- c)** M3 screw to fix FX_{1N}-4EX-BD (2 pieces)
(supplied as accessories)
- d)** External port for optional equipment
- e)** FX_{1N}-4EX-BD (function expansion board)

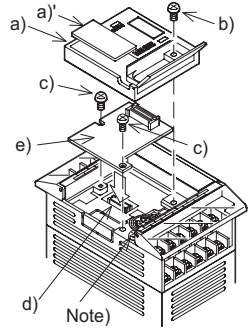

Note: Do not remove this screw on the PLC(FX_{1S}).

- 1) Remove the top cover of the main unit and keep.
- 2) Plug FX_{1N}-4EX-BD **e)** in to the external port **d)**.
- 3) Fix the function expansion board to the main unit with two M3 screws **c)**. (Tightening torque: 0.3 to 0.6 N·m)
- 4) Attach the top cover for use with FX_{1N}-4EX-BD **a)** in place of the original cover.
During attachment, remove **a)'** with a suitable tool, so that the input terminals are exposed.
- 5) Fix the top cover with an M3 screw **b)**. (Tightening torque: 0.3 to 0.6 N·m)

3. Input Wiring

Wiring cautions



Observe the following cautions to avoid electrical shock, short-circuit, disconnection or damage to the unit.

- Do not lay signal cable near to high voltage power cable or house them in the same trunking duct. Effects of noise or surge induction may occur. Keep signal cables a safe distance of more than 100 mm (4") from these power cables.
- Where input signal lines are used over an extended distance consideration for voltage drop and noise interference should be made.
- Twist the end of each stranded cable so that barbed wires are not present.
- Never solder the end of any cables.
- Never connect cables of a non permitted size. Make sure that the number of connected cables is not more than the unit has been designed for.
- Fix cables so that any stress is not directly applied on the terminal block or the cable connection area.
- Tighten the terminals to a torque of 0.5 to 0.6 N·m. Do not tighten terminal screws exceeding the specified torque. Failure to do so may cause equipment failures or malfunctions.

3.1 Applicable cables

- Use AWG26-16 for connection with input equipment.
- Tighten the terminals to a torque of 0.5 to 0.6N·m. Do not tighten terminal screws exceeding the specified torque. Failure to do so may cause equipment failures or malfunctions.
- When using a different type of cable, defective contact of the terminal part is possible. Use a crimp terminal to achieve a good contact.

Linear and sectional area

Linear	Sectional area (mm ²)	Terminal
AWG26	0.1288	Stranded cable: Remove sheath, twist core wires, then connect cable. Single cable: Remove sheath, then connect cable.
⋮	⋮	
AWG16	1.309	

Terminal processing of wire

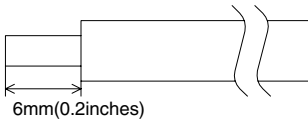

3.2 Wiring of input

Sink

Source

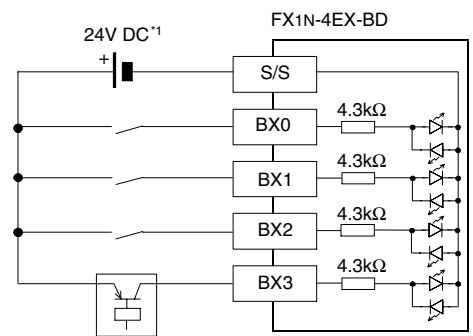
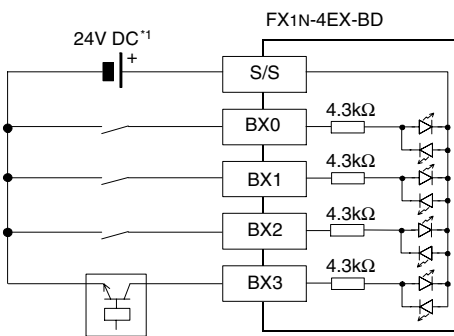

. *1 The service power supply of the PLC main unit can be used.

3.3 Diodes and inputs connected in series;

Vdrop across the diode less than 4V

No more than 2 LEDs should be connected in series.

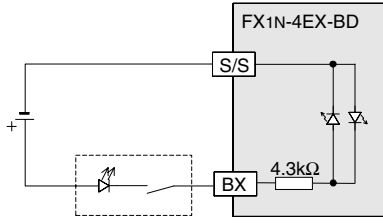

3.4 Resistors and inputs connected in parallel;

Parallel resistance Rp: FX1N-4EX-BD = 15kΩ. If resistance Rp is less than the stated value, then add Rb. See equation 1 for Rb calculation.

Alternatively; Current leakage: FX1N-4EX-BD= 1.5mA. If the current leakage(I) is greater than the stated value, then add Rb. See equation 2 for Rb calculation.

$$\text{Eqn 1 : } R_b \leq \frac{4R_p}{15 - R_p} \text{ (k}\Omega\text{)}$$

$$\text{Eqn 2 : } R_b \leq \frac{6}{I - 1.5} \text{ (k}\Omega\text{)}$$

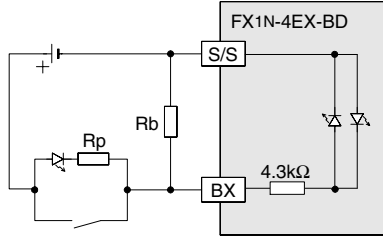

4. Device allocation and program example

4.1 Device allocation

Each input of FX1N-4EX-BD is allocated a special auxiliary relay.

The ON/OFF state of each input is reflected in its corresponding special auxiliary relay.

- BX0 input of FX1N-4EX-BD : M8112
- BX1 input of FX1N-4EX-BD : M8113
- BX2 input of FX1N-4EX-BD : M8114
- BX3 input of FX1N-4EX-BD : M8115

4.2 Program example

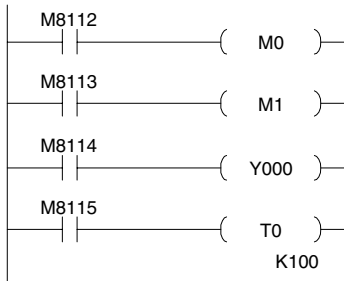

- Use a contact instruction for each special auxiliary relay.

- When the END instruction of the program is executed, the input process is completed. REF (I/O refreshing) instruction cannot be used.
- When input information on FX1N-4EX-BD is used for the operand of each applied instruction as data, only four bit data (K1M8112) can be used.

5. Specifications



Caution

- Do not touch the terminals while power is ON. Electric shock is possible.
- Cleaning and additional tightening of the terminal should only be done after turning OFF the power supply. Electric shock is possible while the power is ON.
- For repair please contact a service representative. Incorrect repair can cause malfunction or electric shock.
- Install and uninstall FX_{1N}-4EX-BD after turning OFF the power supply. Installing and uninstalling while the power supply is ON may cause malfunction.
- Treat as industrial waste when disposing of the product.

5.1 Environmental specifications

The environmental specifications are equivalent to those of the PLC main unit. (Refer to the manual of the PLC main unit.)

5.2 Power supply specifications

Item	Specification
Consumption current	5V DC Supply by PLC.
	24V DC 25mA or less. Supply from external power supply.

5.3 INPUT specifications

Item	Specification
Input signal voltage	24V DC +20% -15%
Input signal current	About 5mA/24V DC
Input ON current	3.5mA or more
Input OFF current	1.5mA or less
Input response time	About 10mS
Input signal form	Without voltage contact or opening collector Transistor
Circuit insulation	Photo coupler
Operation display	LED lighting when photo coupler is driven

Attention

- This product is designed for use in industrial applications.

Note

- Manufactured by: Mitsubishi Electric Corporation
2-7-3 Marunouchi, Chiyoda-ku, Tokyo, 100-8310 Japan
- Manufactured at: Mitsubishi Electric Corporation Himeji Works
840 Chiyoda-machi, Himeji, Hyogo, 670-8677 Japan
- Authorized Representative in the European Community:
Mitsubishi Electric Europe B.V.
Gothaer Str. 8, 40880 Ratingen, Germany

Manual number : JY992D95001

Manual revision : B

Date : October 2010

 **MITSUBISHI ELECTRIC CORPORATION**

HEAD OFFICE : TOKYO BUILDING, 2-7-3 MARUNOUCHI, CHIYODA-KU, TOKYO 100-8310, JAPAN
HIMEJI WORKS : 840, CHIYODA CHO, HIMEJI, JAPAN

FX_{1N}

FX_{1N}-4EX-BD Input Expansion Board

USER'S MANUAL

JY992D95001B

This manual contains text, diagrams and explanations which will guide the reader in the correct installation, safe use and operation of the FX_{1N}-4EX-BD Input Expansion Board and should be read and understood before attempting to install or use the unit. Further information can be found in the associated manuals list below.

Specifications are subject to change without notice

Guidelines for the Safety of the User and Protection of the FX_{1N}-4EX-BD.

This manual has been written to be used by trained and competent personnel. The definition of such a person or persons is as follows:

- Any engineer using the product associated with this manual, should be of a competent nature, trained and qualified to the local and national standards. These engineers should be fully aware of all aspects of safety with regards to automated equipment.
- Any commissioning or service engineer must be of a competent nature, trained and qualified to the local and national standards.
- All operators of the completed equipment should be trained to use that product in a safe and coordinated manner in compliance to established safety practices.

Note: The term 'completed equipment' refers to a third party constructed device which contains or uses the product associated with this manual.

Note's on the Symbols Used in this Manual

At various times through out this manual certain symbols will be used to highlight points of information which are intended to ensure the users personal safety and protect the integrity of equipment.



- Indicates that the identified danger **WILL** cause physical and property damage.



- Indicates that the identified danger could **POSSIBLY** cause physical and property damage.

- Under no circumstances will Mitsubishi Electric be liable or responsible for any consequential damage that may arise as a result of the installation or use of this equipment.
- All examples and diagrams shown in this manual are intended only as an aid to understanding the text, not to guarantee operation. Mitsubishi Electric will accept no responsibility for actual use of the product based on these illustrative examples.
- Owing to the very great variety in possible application of this equipment, you must satisfy yourself as to its suitability for your specific application.

Associated manuals

Manual name	Manual No.	Description
FX _{1S} Series Hardware Manual	JY992D83901	Describes contents related to hardware of FX _{1S} Series PLC such as specifications, wiring and installation.
FX _{1N} Series Hardware Manual	JY992D89301	Describes contents related to hardware of FX _{1N} Series PLC such as specifications, wiring and installation.
FX Programming Manual II	JY992D88101	Describes instructions in FX _{1S} /FX _{1N} /FX _{2N} /FX _{2NC} Series.

1. Introduction

The FX_{1N}-4EX-BD Input Expansion Board (hereafter referred to as "FX_{1N}-4EX-BD" or "Function expansion board") is a function expansion board to be installed in the FX_{1S} or FX_{1N} series programmable controller (hereafter referred to as "PLC"), to increase the input of four points.

1.1 Features of the FX_{1N}-4EX-BD

- Additional increase of four input points.
- Internal mounting in the top of the PLC meaning no need for change to the installation area of the PLC.
- Additional inputs have special auxiliary relays allocated to each point, which are turned ON and OFF depending on the input state of the FX_{1N}-4EX-BD.
As special auxiliary relays are used in the PLC program for the input points, the additional inputs are not included in the regular system I/O count.

1.2 External Dimensions and Each Part Name

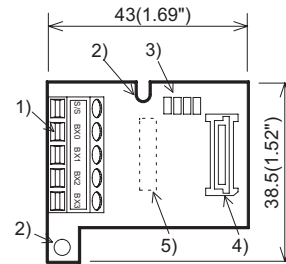

Dimensions: mm (inches)

Accessories : Top cover for board 1
M3 screw to mount board 2
M3 screw to fix top cover 1

- Input terminal.
S/S : Power supply terminal
BX0 : Terminal of input BX0
BX1 : Terminal of input BX1
BX2 : Terminal of input BX2
BX3 : Terminal of input BX3
The top face of this connector is higher than the top face of the PLC panel cover by approximately 7 mm.
- Mounting hole (2-φ3.5(0.14"))
- Input LED
BX0 LED : The LED lights when BX0 is turn on.
BX1 LED : The LED lights when BX1 is turn on.
BX2 LED : The LED lights when BX2 is turn on.
BX3 LED : The LED lights when BX3 is turn on.
- External port for display module FX_{1N}-5DM or memory cassette FX_{1N}-EEPROM-8L
- External connector for PLC

1.3 System configuration

- Only one function expansion board can be used on one FX_{1S} or FX_{1N} series PLC main unit. Do not try to install two or more expansion boards.
- FX_{1N}-4EX-BD can be used together with an FX_{1N}-5DM. Refer to the FX_{1S} or FX_{1N} HARDWARE MANUAL when using the FX_{1N}-4EX-BD together with an FX_{1N}-5DM.
- When using with the memory cassette FX_{1N}-EEPROM-8L, only program transfer is possible. (The memory cassette cannot be connected permanently)

1.4 Applicable PLC

Series name	Applicable version
FX _{1S}	V2.0 or later
FX _{1N}	V2.0 or later

2. Installation



Caution

- Do not use the function expansion board in environments that contain excessive or conductive dust, corrosive or flammable gas, moisture or rain, excessive heat, regular impact shocks or excessive vibration.
Use in these environment may cause electric shock, fire, malfunction, damage or deterioration of the product.
- Cut off all phases of power source before installing / removing or performing wiring work on the unit in order to avoid electric shock or damage of product.
- After the installation and wiring etc. replace the PLCs top cover before power ON.
- Securely install the function expansion board, and fix to the PLC.
Defective contact can cause malfunction.

2.1 Mounting

Turn off all power to the PLC before installing the FX_{1N}-4EX-BD.

- Top cover for use with FX_{1N}-4EX-BD (supplied as an accessory)
- M3 screw to fix top cover (supplied as an accessory)
- M3 screw to fix FX_{1N}-4EX-BD (2 pieces) (supplied as accessories)
- External port for optional equipment
- FX_{1N}-4EX-BD (function expansion board)

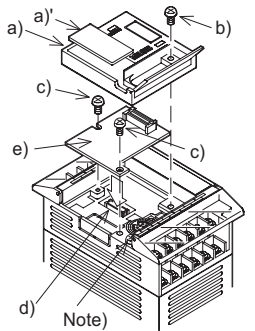

Note: Do not remove this screw on the PLC(FX_{1S}).

- Remove the top cover of the main unit and keep.
- Plug FX_{1N}-4EX-BD **e**) in to the external port **d**).
- Fix the function expansion board to the main unit with two M3 screws **c**). (Tightening torque: 0.3 to 0.6 N·m)
- Attach the top cover for use with FX_{1N}-4EX-BD **a**) in place of the original cover. During attachment, remove **a**)' with a suitable tool, so that the input terminals are exposed.
- Fix the top cover with an M3 screw **b**). (Tightening torque: 0.3 to 0.6 N·m)

3. Input Wiring

Wiring cautions



Observe the following cautions to avoid electrical shock, short-circuit, disconnection or damage to the unit.

- Do not lay signal cable near to high voltage power cable or house them in the same trunking duct. Effects of noise or surge induction may occur. Keep signal cables a safe distance of more than 100 mm (4") from these power cables.
- Where input signal lines are used over an extended distance consideration for voltage drop and noise interference should be made.
- Twist the end of each stranded cable so that barbed wires are not present.
- Never solder the end of any cables.
- Never connect cables of a non permitted size. Make sure that the number of connected cables is not more than the unit has been designed for.
- Fix cables so that any stress is not directly applied on the terminal block or the cable connection area.
- Tighten the terminals to a torque of 0.5 to 0.6 N·m. Do not tighten terminal screws exceeding the specified torque. Failure to do so may cause equipment failures or malfunctions.

3.1 Applicable cables

- Use AWG26-16 for connection with input equipment.
- Tighten the terminals to a torque of 0.5 to 0.6N·m. Do not tighten terminal screws exceeding the specified torque. Failure to do so may cause equipment failures or malfunctions.
- When using a different type of cable, defective contact of the terminal part is possible. Use a crimp terminal to achieve a good contact.

Linear and sectional area

Linear	Sectional area (mm ²)	Terminal
AWG26	0.1288	Stranded cable: Remove sheath, twist core wires, then connect cable. Single cable: Remove sheath, then connect cable.
AWG16	1.309	

Terminal processing of wire



3.2 Wiring of input

Sink

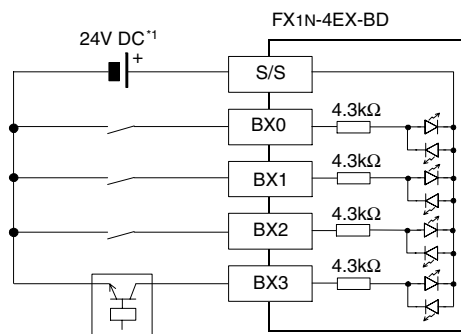

Source

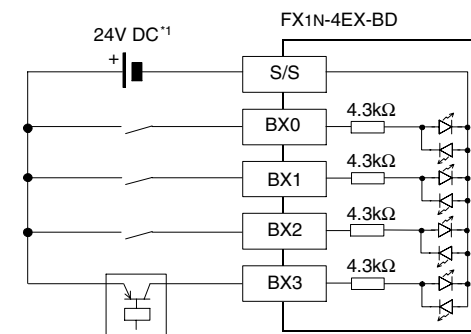

*1 The service power supply of the PLC main unit can be used.

3.3 Diodes and inputs connected in series;

Vdrop across the diode less than 4V

No more than 2 LEDs should be connected in series.

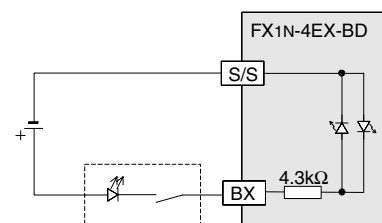

3.4 Resistors and inputs connected in parallel;

Parallel resistance Rp: FX1N-4EX-BD = 15kΩ. If resistance Rp is less than the stated value, then add Rb. See equation 1 for Rb calculation.

Alternatively; Current leakage: FX1N-4EX-BD= 1.5mA. If the current leakage(I) is greater than the stated value, then add Rb. See equation 2 for Rb calculation.

$$\text{Eqn 1 : } Rb \leq \frac{4Rp}{15 - Rp} \text{ (k}\Omega\text{)}$$

$$\text{Eqn 2 : } Rb \leq \frac{6}{I - 1.5} \text{ (k}\Omega\text{)}$$

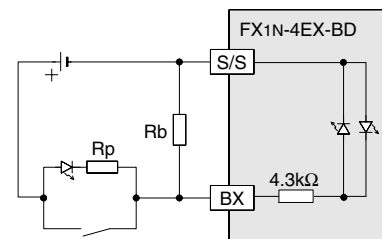

4. Device allocation and program example

4.1 Device allocation

Each input of FX1N-4EX-BD is allocated a special auxiliary relay.

The ON/OFF state of each input is reflected in its corresponding special auxiliary relay.

- BX0 input of FX1N-4EX-BD : M8112
- BX1 input of FX1N-4EX-BD : M8113
- BX2 input of FX1N-4EX-BD : M8114
- BX3 input of FX1N-4EX-BD : M8115

4.2 Program example

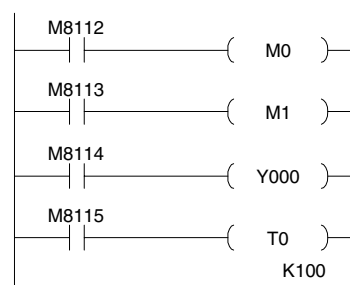

- Use a contact instruction for each special auxiliary relay.

- When the END instruction of the program is executed, the input process is completed. REF (I/O refreshing) instruction cannot be used.
- When input information on FX1N-4EX-BD is used for the operand of each applied instruction as data, only four bit data (K1M8112) can be used.

5. Specifications



Caution

- Do not touch the terminals while power is ON. Electric shock is possible.
- Cleaning and additional tightening of the terminal should only be done after turning OFF the power supply. Electric shock is possible while the power is ON.
- For repair please contact a service representative. Incorrect repair can cause malfunction or electric shock.
- Install and uninstall FX1N-4EX-BD after turning OFF the power supply. Installing and uninstalling while the power supply is ON may cause malfunction.
- Treat as industrial waste when disposing of the product.

5.1 Environmental specifications

The environmental specifications are equivalent to those of the PLC main unit. (Refer to the manual of the PLC main unit.)

5.2 Power supply specifications

Item	Specification	
Consumption current	5V DC	Supply by PLC.
	24V DC	25mA or less. Supply from external power supply.

5.3 INPUT specifications

Item	Specification
Input signal voltage	24V DC +20% -15%
Input signal current	About 5mA/24V DC
Input ON current	3.5mA or more
Input OFF current	1.5mA or less
Input response time	About 10mS
Input signal form	Without voltage contact or opening collector Transistor
Circuit insulation	Photo coupler
Operation display	LED lighting when photo coupler is driven

Attention

- This product is designed for use in industrial applications.

Note

- Manufactured by: Mitsubishi Electric Corporation
2-7-3 Marunouchi, Chiyoda-ku, Tokyo, 100-8310 Japan
- Manufactured at: Mitsubishi Electric Corporation Himeji Works
840 Chiyoda-machi, Himeji, Hyogo, 670-8677 Japan
- Authorized Representative in the European Community:
Mitsubishi Electric Europe B.V.
Gothaer Str. 8, 40880 Ratingen, Germany

Manual number : JY992D95001

Manual revision : B

Date : October 2010

MITSUBISHI ELECTRIC CORPORATION

HEAD OFFICE : TOKYO BUILDING, 2-7-3 MARUNOUCHI, CHIYODA-KU, TOKYO 100-8310, JAPAN
HIMEJI WORKS : 840, CHIYODA CHO, HIMEJI, JAPAN